

SUBMITTAL DATA SHEET	CH-36LCFCI	CH-HYP36LCUO
-----------------------------	-------------------	---------------------

Job Name:
 Location:
 Engineer:
 Submitted to:
 Submitted by:
 Reference:

Date:
 Approval:
 Construction:
 Unit #:
 Drawing #:



OPERATION TEMPERATURE RANGE

Indoor		Outdoor	
cooling	heating	cooling	heating
62~90°F	32~86°F	-22~122°F	-22~86°F

ELECTRICAL

	Power supply	208-230V/ 60Hz, 1Ph
	MCA	39
	MFA	50
Outdoor fan motor	Input	126 W
	RLA	0.39 A
Compressor	Capacity	44,015 Btu/h

MCA: Minimum Circuit Ampacity **MFA:** Max. fuse A **RLA:** Rated Load

PIPING

Refrigerant piping Liquid side/Gas side	3/8" - 5/8" in
Max. refrigerant pipe length	213 ft
Max. difference in level	98 ft

WIRING

Connection wiring	16AWG*4 Stranded, unshielded
-------------------	------------------------------



This warranty should be registered on our web-site www.cooperandhunter.us within 60 days of installation. The warranty is only valid when installed by a Licensed HVAC Technician. A warranty period of Seven (7) years on compressor to the original registered end-user. A warranty period of Five (5) years on all parts to the original registered end user. Warranty applies only to products remaining in their original installation location.

INDOOR SPECIFICATION

Air Flow (Hi/Mi/Lo)	1037/917/638 CFM
Noise Level (Hi/Mi/Lo)	54/49/43 dB(A)
Unit Dimension (WxDxH)	50.6x26.6x9.3 in
Net/Gross Weight	69/81.6 lb

OUTDOOR SPECIFICATION

Air flow	4470 CFM
Noise Level	65 dB(A)
Dimension (WxDxH)	37.5x16.3x52.5 in
Net/Gross weight	222.3/248 lb
Refrigerant type/Quantity	R410A/148 oz
Refrigerant precharge	25 ft
Additional charge for each, ft	0.32 oz

PERFORMANCE AND EFFICIENCY

Cooling		Heating	
36,000 Btu/h		38,000 Btu/h	
SEER	16	HSPF 4	10
EER	8	HSPF 5	8.7

SUBMITTAL DATA SHEET	CH-36LCFCI	CH-HYP36LCUO
----------------------	------------	--------------

INDOOR UNIT

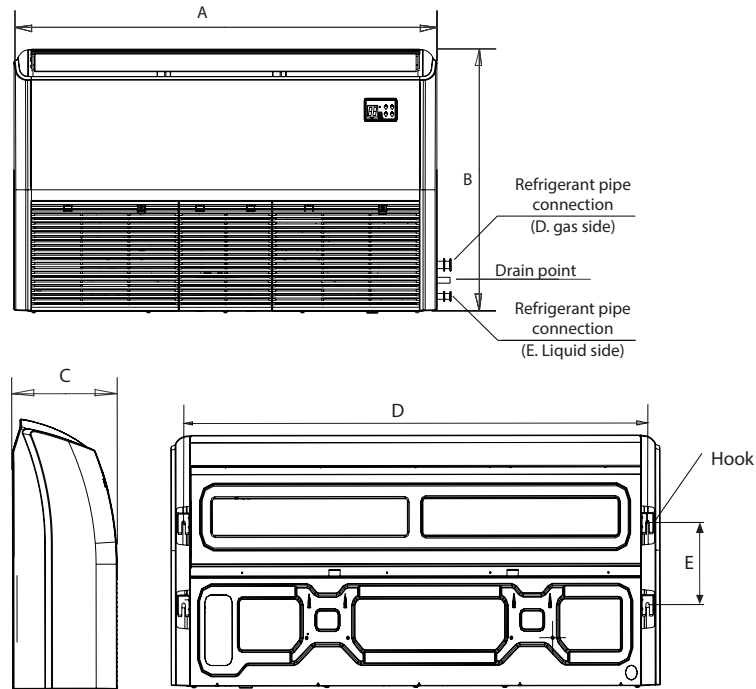

Unit Dimensions, in			Mounting Dimensions, in
A	B	C	D
50.6	26.6	9.3	47.2

OUTDOOR UNIT

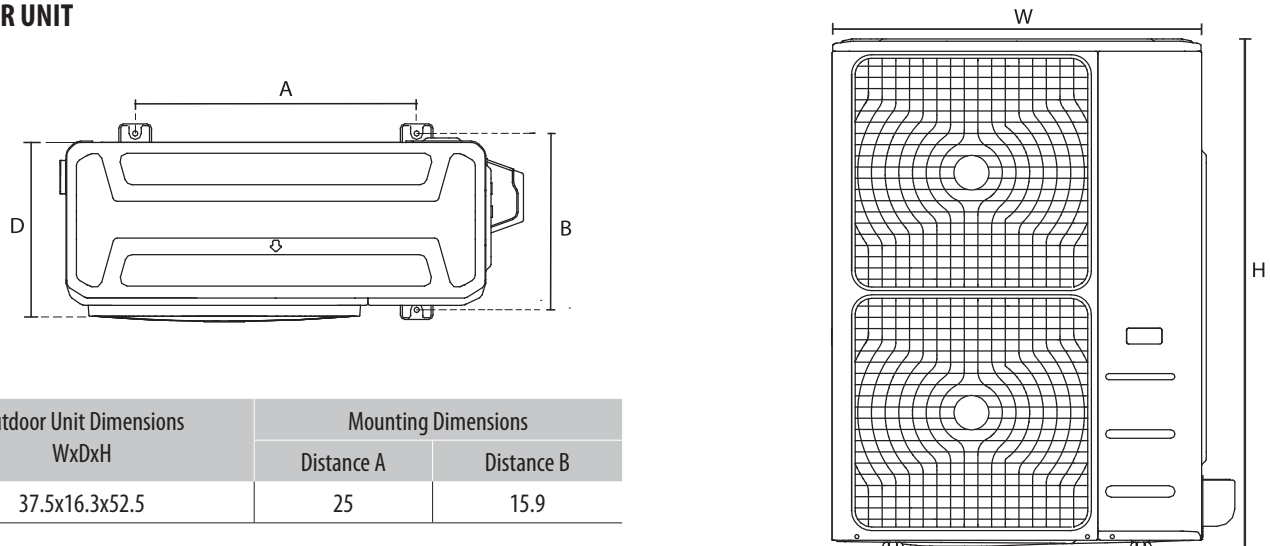

Outdoor Unit Dimensions WxDxH	Mounting Dimensions	
	Distance A	Distance B
37.5x16.3x52.5	25	15.9