

SUBMITTAL DATA SHEET	CH-D36SPHWM-230VI	CH-36SPH-230VO
-----------------------------	--------------------------	-----------------------

Job Name:
 Location:
 Engineer:
 Submitted to:
 Submitted by:
 Reference:

Date:
 Approval:
 Construction:
 Unit #:
 Drawing #:



PERFORMANCE AND EFFICIENCY

Cooling		Heating	
36,000 Btu/h		36,000 Btu/h	
EER	8.5	HSPF4/ HSPF5	8.5/7.0
SEER	16	COP	2.81

OPERATION TEMPERATURE RANGE

Indoor		Outdoor	
cooling	heating	cooling	heating
62~90°F	32~86°F	-13~122°F	-13~86°F

ELECTRICAL

Power supply	208-230V/ 60Hz, 1Ph
MCA	25
MFA	35

MCA: Minimum Circuit Ampacity **MFA:** Max. fuse A

PIPING

Refrigerant piping Liquid side/Gas side	3/8" - 5/8"
Max. refrigerant pipe length	213 ft
Max. difference in level	98 ft

WIRING

Connection wiring	16AWG*4 Stranded, unshielded
-------------------	------------------------------



This warranty should be registered on our web-site www.cooperandhunter.us within 60 days of installation. The warranty is only valid when installed by a Licensed HVAC Technician. A warranty period of Seven (7) years on compressor to the original registered end-user. A warranty period of Five (5) years on all parts to the original registered end user. Warranty applies only to products remaining in their original installation location.

INDOOR SPECIFICATION

Air Flow (Hi/Mi/Lo)	676.5/588.2/470.6 CFM
Noise Level (Hi/Mi/Lo)	48.5/44/38 dB(A)
Unit Dimension (WxDxH)	46.7x10.2x13.5 in
Net/Gross Weight	37.7/48.7 lb

OUTDOOR SPECIFICATION

Air flow	2235 CFM
Noise Level	59 dB(A)
Dimension (WxDxH)	37.2x16.1x31.9 in
Net/Gross weight	143.7/157.6 lb
Refrigerant type/Quantity	R410A/119.9 oz
Refrigerant precharge	20 ft
Additional charge for each ft	0.21 oz

SUBMITTAL DATA SHEET

CH-D36SPHWM-230VI

CH-36SPH-230VO

INDOOR UNIT

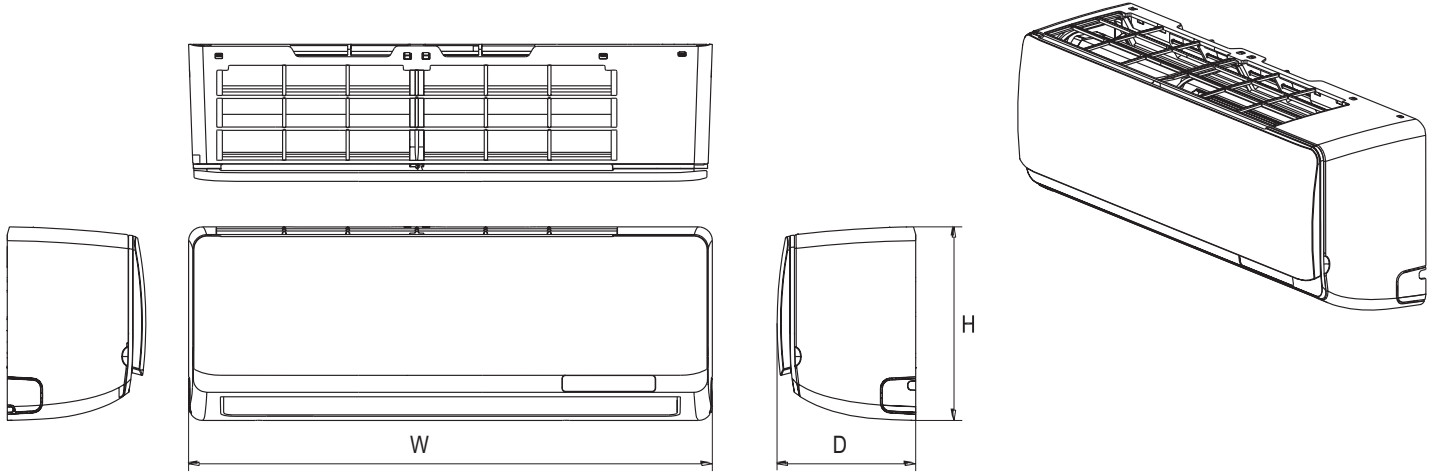

Indoor Unit Dimensions, in		
W	D	H
46.7	10.1	13.4

OUTDOOR UNIT

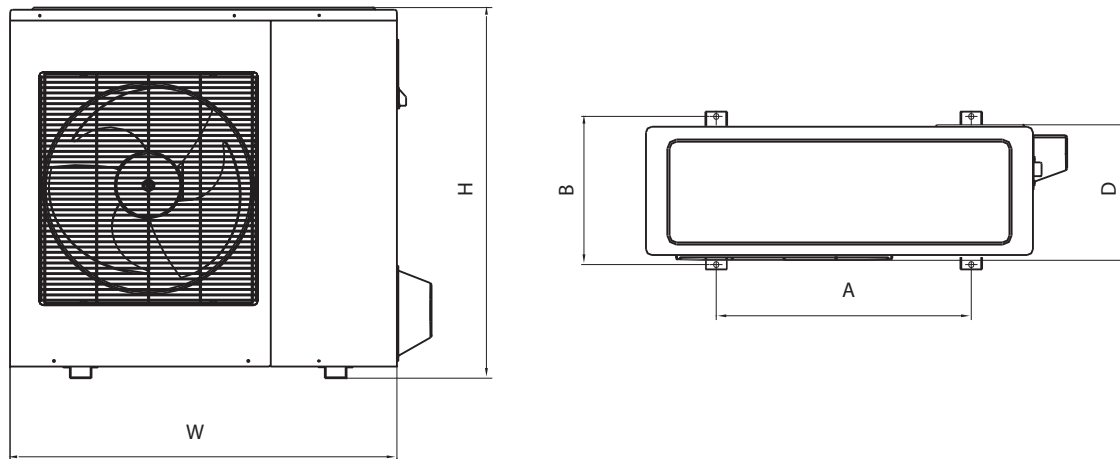

Outdoor Unit Dimensions WxDxH, in	Mounting Dimensions, in	
	Distance A	Distance B
37.2x16.1x31.9	26.5	15.9