

<b>SUBMITTAL DATA SHEET</b>	<b>CH-D09MSPHWM-230VI</b>	<b>CH-09SPH-230VO</b>
-----------------------------	---------------------------	-----------------------

Job Name: .....  
 Location: .....  
 Engineer: .....  
 Submitted to: .....  
 Submitted by: .....  
 Reference: .....

Date: .....  
 Approval: .....  
 Construction: .....  
 Unit #: .....  
 Drawing #: .....



This warranty should be registered on our web-site [www.cooperandhunter.us](http://www.cooperandhunter.us) within 60 days of installation. The warranty is only valid when installed by a Licensed HVAC Technician. A warranty period of Seven (7) years on compressor to the original registered end-user. A warranty period of Five (5) years on all parts to the original registered end user. Warranty applies only to products remaining in their original installation location.

Heating/ Cooling	Outdoor Dry Bulb	Indoor Dry Bulb	Unit	Min	Rated	Max
Heating	5°F	70°F	Btu/h	2,050	-	7,989
			kW	0.42	-	1.17
			COP	1.43	-	2
	17°F	70°F	Btu/h	1,632	5,800	10,085
			kW	0.25	0.62	1.3
			COP	1.91	2.74	2.27
	47°F	70°F	Btu/h	3,410	9,800	13,357
			kW	0.26	0.76	1.1
			COP	3.84	3.78	3.56
Cooling	82°F	80°F	Btu/h	1,372	-	7,755
			kW	0.09	-	0.5
			COP	4.47	-	4.55
	95°F	80°F	Btu/h	746	9,000	10,389
			kW	0.15	0.6	0.89
			COP	1.46	4.4	3.42

### INDOOR SPECIFICATION

Air Flow (Hi/Mi/Lo)	370/268/196 CFM
Noise Level (Hi/Mi/Lo)	41.7/33.4/26.5 dB(A)
Unit Dimension (WxDxH)	32.87x7.80x11.02 in
Net/Gross Weight	19.84/25.35 lb

### OUTDOOR SPECIFICATION

Air flow	1177 CFM
Noise Level	55 dB(A)
Dimension (WxDxH)	30.31x11.81x21.85 in
Net/Gross weight	61.73/66.8 lb
Refrigerant type/Quantity	R410A/38.8 oz
Refrigerant precharge	25 ft
Additional charge for each ft	0.16 oz

### PERFORMANCE AND EFFICIENCY

Cooling		Heating	
9,000 Btu/h		9,800 Btu/h	
SEER	23.5	HSPF Region IV	10.8
EER	14.9		

### OPERATION TEMPERATURE RANGE

Indoor		Outdoor	
cooling	heating	cooling	heating
62~90°F	32~86°F	-13~122°F	-13~86°F

### ELECTRICAL

Power supply	208-230V/ 60Hz, 1Ph
MCA	10 A
MFA	15 A

**MCA:** Minimum Circuit Ampacity    **MFA:** Max. fuse A

### PIPING

Refrigerant piping Liquid side/Gas side	1/4 - 3/8 in
Max. refrigerant pipe length	82 ft
Max. difference in level	33 ft

SUBMITTAL DATA SHEET

CH-D09MSPHWM-230VI

CH-09SPH-230VO

### INDOOR UNIT

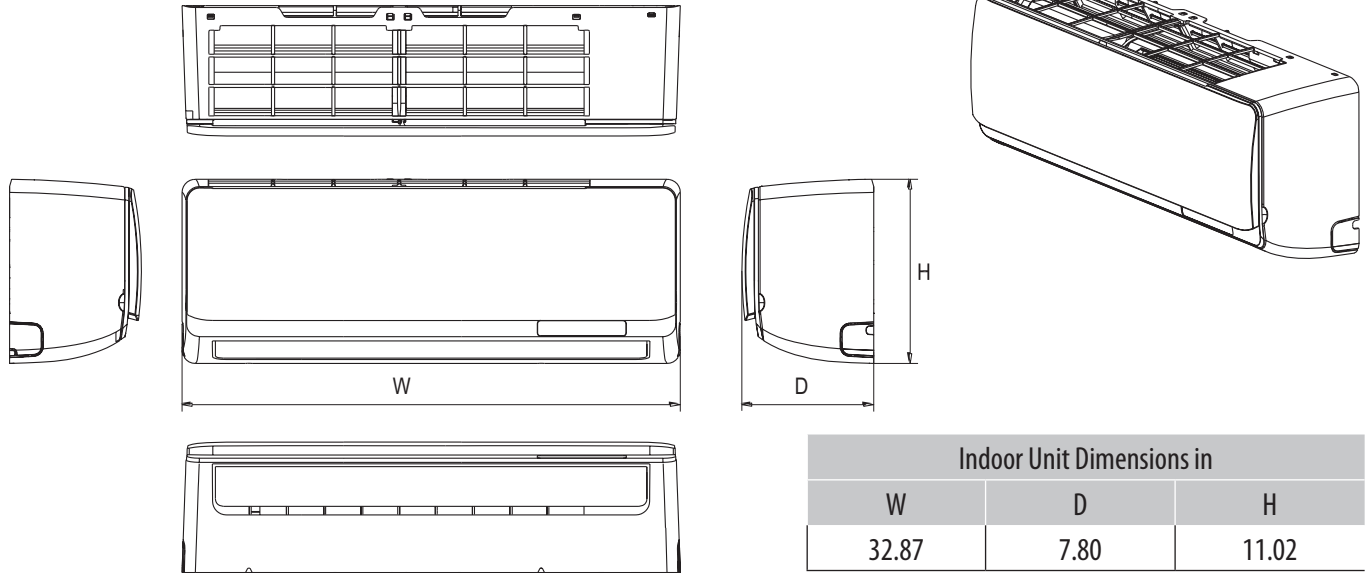

### OUTDOOR UNIT

