

SUBMITTAL DATA SHEET
CH-60LCDTUI

Job Name:
 Location:
 Engineer:
 Submitted to:
 Submitted by:
 Reference:

Date:
 Approval:
 Construction:
 Unit #:
 Drawing #:

PERFORMANCE AND EFFICIENCY

Cooling		Heating	
57,000 Btu/h		62,000 Btu/h	
SEER	18.0	HSPF4/ HSPF5	9.0/7.68
EER	10.0	COP	3.6

OPERATION TEMPERATURE RANGE

Cooling	Heating
62~90°F	32~86°F

ELECTRICAL

Power supply	208-230V/ 60Hz, 1Ph
MCA	36
MFA	50
Fan motor	
Input	420 W
RLA	3.65 A

MCA: Minimum Circuit Ampacity **MFA:** Max. fuse A **RLA:** Rated Load

PIPING

Refrigerant piping Liquid side/Gas side	3/8 - 3/4 in
---	--------------



This warranty should be registered on our web-site www.cooperandhunter.us within 60 days of installation. The warranty is only valid when installed by a Licensed HVAC Technician. A warranty period of Seven (7) years on compressor to the original registered end-user. A warranty period of Five (5) years on all parts to the original registered end user. Warranty applies only to products remaining in their original installation location.

FUTURES

- Flexible Installation
- Fresh Air Function
- Wired Control
- Multi-Channel Air Distribution
- Built-In Water Pump
- Golden fin for outdoor and indoor
- Lower Noise
- Higher Pipe Limits
- Slim Design

UNIT SPECIFICATION

Air Flow (Hi/Mi/Lo)	2157/1710/1262 CFM
Noise Level (Hi/Mi/Lo)	50.5/47/43 dB(A)
Unit Dimension(W*D*H)	55.12/33.78/17.32 in
Net/Gross Weight	163.14/189.6 lb

SUBMITTAL DATA SHEET

CH-60LCDTUI

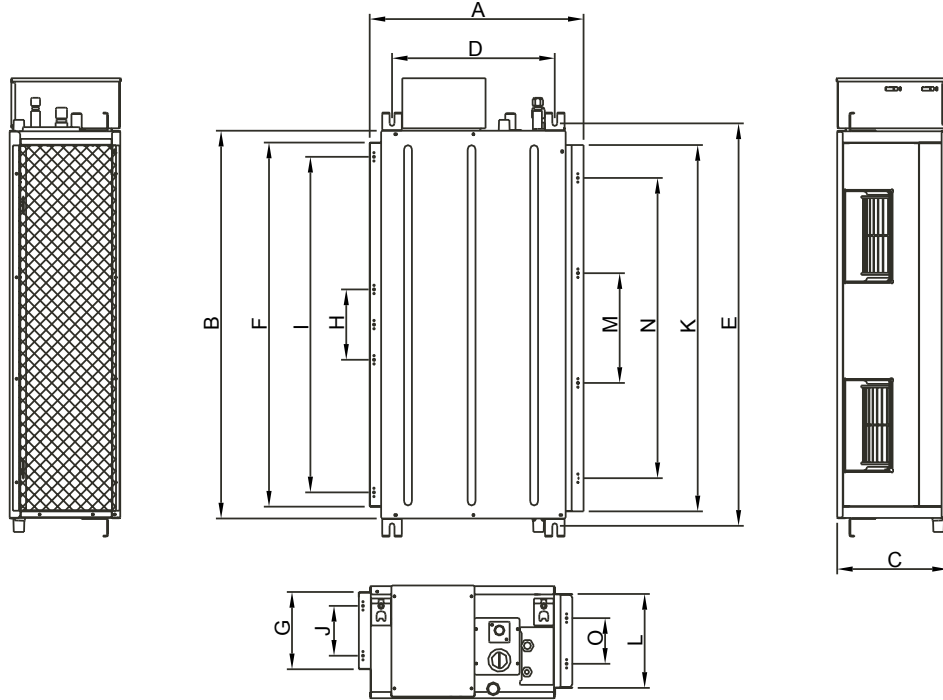

Outline dimension			Size of mounted lug		Air outlet opening size (symmetry of air outlet opening)					air inlet opening size (symmetry of air inlet opening)				
A	B	C	D	E	F	G	H	I	J	K	L	M	N	O
33.78	55.12	17.32	27.5	56.5	46.7	15	20	39.3	11	46.7	12.8	20	39.3	11