

SUBMITTAL DATA SHEET	CH-36LCDTUI	CH-HYP36LCUO
----------------------	-------------	--------------

Job Name:
 Location:
 Engineer:
 Submitted to:
 Submitted by:
 Reference:

Date:
 Approval:
 Construction:
 Unit #:
 Drawing #:



PERFORMANCE AND EFFICIENCY

Cooling		Heating	
36,000 Btu/h		40,000 Btu/h	
SEER	16.5	HSPF4/HSPF5	11.5/10
EER	9	COP	3.37

OPERATION TEMPERATURE RANGE

Indoor		Outdoor	
cooling	heating	cooling	heating
62~90°F	32~86°F	-22~122°F	-22~86°F



This warranty should be registered on our website www.cooperandhunter.us within 60 days of installation. The warranty is only valid when installed by a Licensed HVAC Technician. A warranty period of Seven (7) years on compressor to the original registered end-user. A warranty period of Five (5) years on all parts to the original registered end user. Warranty applies only to products remaining in their original installation location.



SOPHIA Hyper DUCT TYPE

SUBMITTAL DATA SHEET	CH-36LCDTUI	CH-HYP36LCUO
----------------------	-------------	--------------

SPECIFICATIONS

Indoor Model			Hyper Heat Series
CH-36LCDTUI			CH-36LCDTUI
Power supply		V,Hz,Ph	208/230V, 1Ph,60Hz
Cooling	Capacity	Btu/h	36,000
	Input	W	4,000
	Rated current	A	18.3
	EER	Btu/W	9
	SEER		16.5
Heating at 47F	Capacity	Btu/h	40,000
	Input	W	3,478
	Rated current	A	15.9
	COP	W/W	3.37
	HSPF4		11.5
	HSPF5		10
Minimum circuit ampacity		A	5
Max.fuse		A	15
Indoor Fan Motor	Qty		1
	Input	W	250
	RLA	A	2.45
Indoor air flow (Hi/Med/Lo) (No duct)		CFM	1,082/912/703
ESP	Range	Pa	0-160
	Range	In. wg.	0-0.64
Indoor noise level (Hi/Med/Lo)		dB(A)	45.5/42/39
Indoor Unit	Dimension (WxDxH)	inch	57x30.25x9.8
	Packing (WxDxH)	inch	62x32x12
	Net/Gross weight	lbs	106/122
Design pressure		PSIG	550/340 PSIG
Drainage water pipe diameter		inch	1
Refrigerant piping	Liquid side/ Gas side	inch	3/8" / 5/8"
Controller			Wired control
Room Temperature	Cooling	°F	62~90
	Heating	°F	32~86
Operation Temperature		°F	62~86
Outdoor Model			CH-HYP36LCUO
Power supply		V,Hz,Ph	208-230V,60Hz, 1Ph
Minimum circuit ampacity		A	39
Max. fuse		A	50
Compressor	Model		ATF235D22UMT
	Type		ROTARY
	Brand		GMCC
	Capacity	Btu/h	44,015
	Input	W	3,565
	Refrigerant oil	oz	49.4 ESTER OIL VG74



SOPHIA Hyper

DUCT TYPE

SUBMITTAL DATA SHEET	CH-36LCDTUI	CH-HYP36LCU0
----------------------	-------------	--------------

SPECIFICATIONS

Outdoor Fan Motor	Qty		2
	Input	W	126
	RLA	A	0.39
	Speed	r/min	900
Outdoor air flow (Max.)		CFM	4,470
Outdoor noise level		dB(A)	65
Throttle type			Capillary +EXV
Outdoor Unit	Dimension (WxDxH)	inch	41.5x17.5x52.5
	Packing (WxDxH)	inch	43.11x19.5x58.25
	Net/Gross weight	lbs	135.58/148.81
Refrigerant	Type/Quantity	Oz	R410A/148
Refrigerant precharge		ft	25
Additional charge for each ft		oz	0.32
Design pressure		PSIG	550/340
Refrigerant piping	Liquid side/ Gas side	inch	3/8" / 5/8"
	Max. Pipe Length	ft	213
	Max. Difference in Level	ft	98
Ambient Temperature	Cooling	°F	-22~122
	Heating	°F	-22~86

SUBMITTAL DATA SHEET	CH-36LCDTUI	CH-HYP36LCUO
----------------------	-------------	--------------

INDOOR UNIT

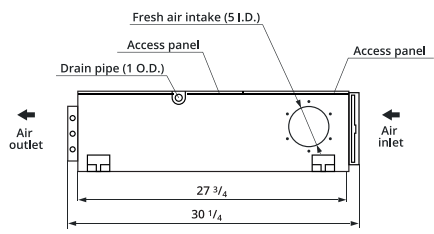
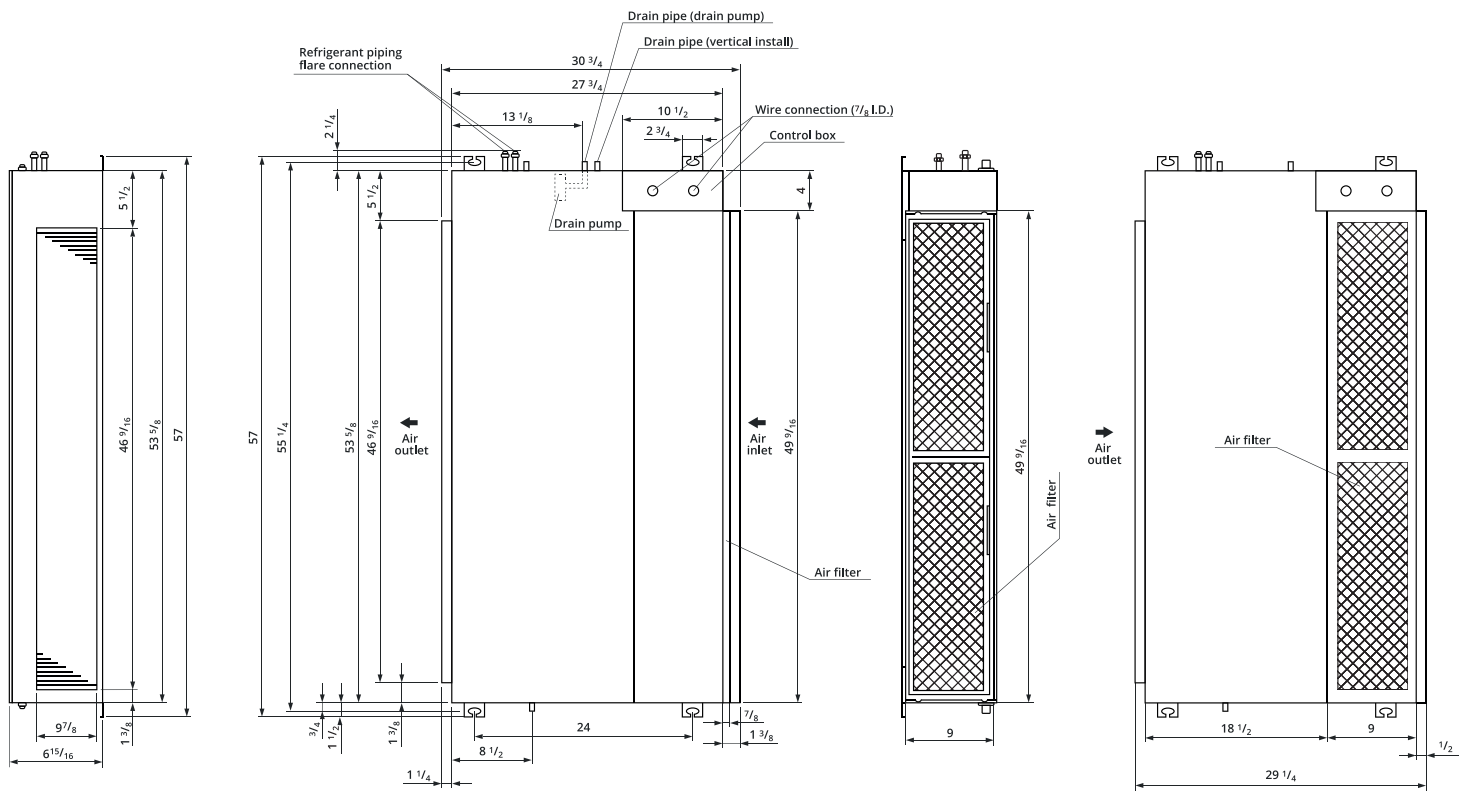
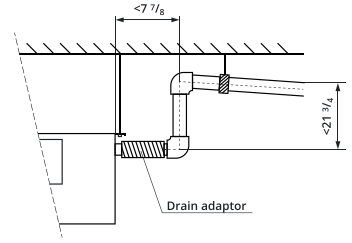
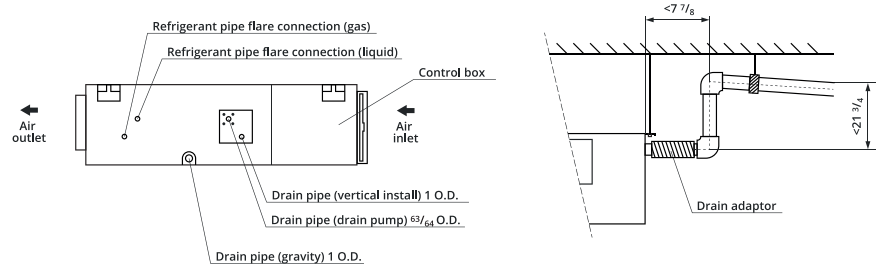

SUBMITTAL DATA SHEET

CH-36LCDTUI

CH-HYP36LCU0

OUTDOOR UNIT

