

SUBMITTAL DATA SHEET	CH-M24DTUI	CH-24LCU/O
----------------------	------------	------------

Job Name:
 Location:
 Engineer:
 Submitted to:
 Submitted by:
 Reference:

Date:
 Approval:
 Construction:
 Unit #:
 Drawing #:



PERFORMANCE AND EFFICIENCY

Cooling		Heating	
24,000 Btu/h		24,000 Btu/h	
SEER	20.5	HSPF4/HSPF5	12.5
EER	12.5	COP	3.81

OPERATION TEMPERATURE RANGE

Indoor		Outdoor	
cooling	heating	cooling	heating
62~90°F	32~86°F	-22~122°F	-22~86°F



This warranty should be registered on our website www.cooperandhunter.us within 60 days of installation. The warranty is only valid when installed by a Licensed HVAC Technician. A warranty period of Seven (7) years on compressor to the original registered end-user. A warranty period of Five (5) years on all parts to the original registered end user. Warranty applies only to products remaining in their original installation location.

SUBMITTAL DATA SHEET	CH-M24DTUI	CH-24LCU/O
-----------------------------	-------------------	-------------------

SPECIFICATIONS

Indoor Model			Hyper Heat Series
Indoor Model			CH-M24DTUI
Power supply		V,Hz,Ph	208/230V, 1Ph,60Hz
Cooling	Capacity	Btu/h	24,000
	Input	W	1,920
	Rated current	A	8.52
	EER	Btu/W	12.5
	SEER		20.5
Heating at 47F	Capacity	Btu/h	24,000
	Input	W	1,846
	Rated current	A	8.19
	COP	W/W	3.81
	HSPF4		12.5
	HSPF5		10.6
Minimum circuit ampacity		A	20
Max.fuse		A	30
Indoor Fan Motor	Qty		1
	Input	W	90
	RLA	A	1.5
Indoor air flow (Hi/Med/Lo) (No duct)		CFM	776/694/435
ESP	Range	Pa	0-160
	Range	In. wg.	0-0.64
Indoor noise level (Hi/Med/Lo)		dB(A)	44/41/38
Indoor Unit	Dimension (WxDxH)	inch	46.75x30.47x9.8
	Packing (WxDxH)	inch	51.38x31.69x12.01
	Net/Gross weight	lbs	86.86/102.95
Design pressure		PSIG	550/340 PSIG
Drainage water pipe diameter		inch	1
Refrigerant piping	Liquid side/ Gas side	inch	3/8" / 5/8"
Controller			Wired control
Room Temperature	Cooling	°F	62~ 90
	Heating	°F	32~ 86
Operation Temperature		°F	62~86
Outdoor Model			CH-24LCU/O
Power supply		V,Hz,Ph	208-230V,60Hz, 1Ph
Minimum circuit ampacity		A	20
Max. fuse		A	30
Compressor	Model		ATF235D22UMT
	Type		ROTARY
	Brand		GMCC
	Capacity	Btu/h	24,345
	Input	W	1,970
	Refrigerant oil	oz	POE(VG74)/22.7



SUBMITTAL DATA SHEET	CH-M24DTUI	CH-24LCU/0
-----------------------------	-------------------	-------------------

SPECIFICATIONS

Outdoor Fan Motor	Qty		1
	Input	W	150
	RLA	A	0.5
	Speed	r/min	810
Outdoor air flow (Max.)		CFM	2,354
Outdoor noise level		dB(A)	61
Throttle type			Capillary +EXV
Outdoor Unit	Dimension (WxDxH)	inch	41.75x18x31.75
	Packing (WxDxH)	inch	42.91x19.69x34.45
	Net/Gross weight	lbs	135.58/148.81
Refrigerant	Type/Quantity	Oz	R410A/91.7
Refrigerant precharge		ft	25
Additional charge for each ft		oz	0.32
Design pressure		PSIG	550/340
Refrigerant piping	Liquid side/ Gas side	inch	3/8" / 5/8"
	Max. Pipe Length	ft	164
	Max. Difference in Level	ft	82
Ambient Temperature	Cooling	°F	-22~122
	Heating	°F	-22~86

SUBMITTAL DATA SHEET	CH-M24DTUI	CH-24LCU/O
----------------------	------------	------------

INDOOR UNIT

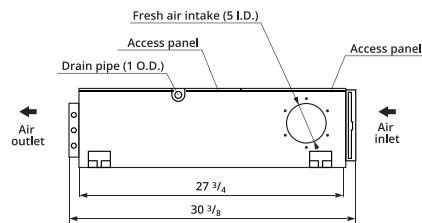
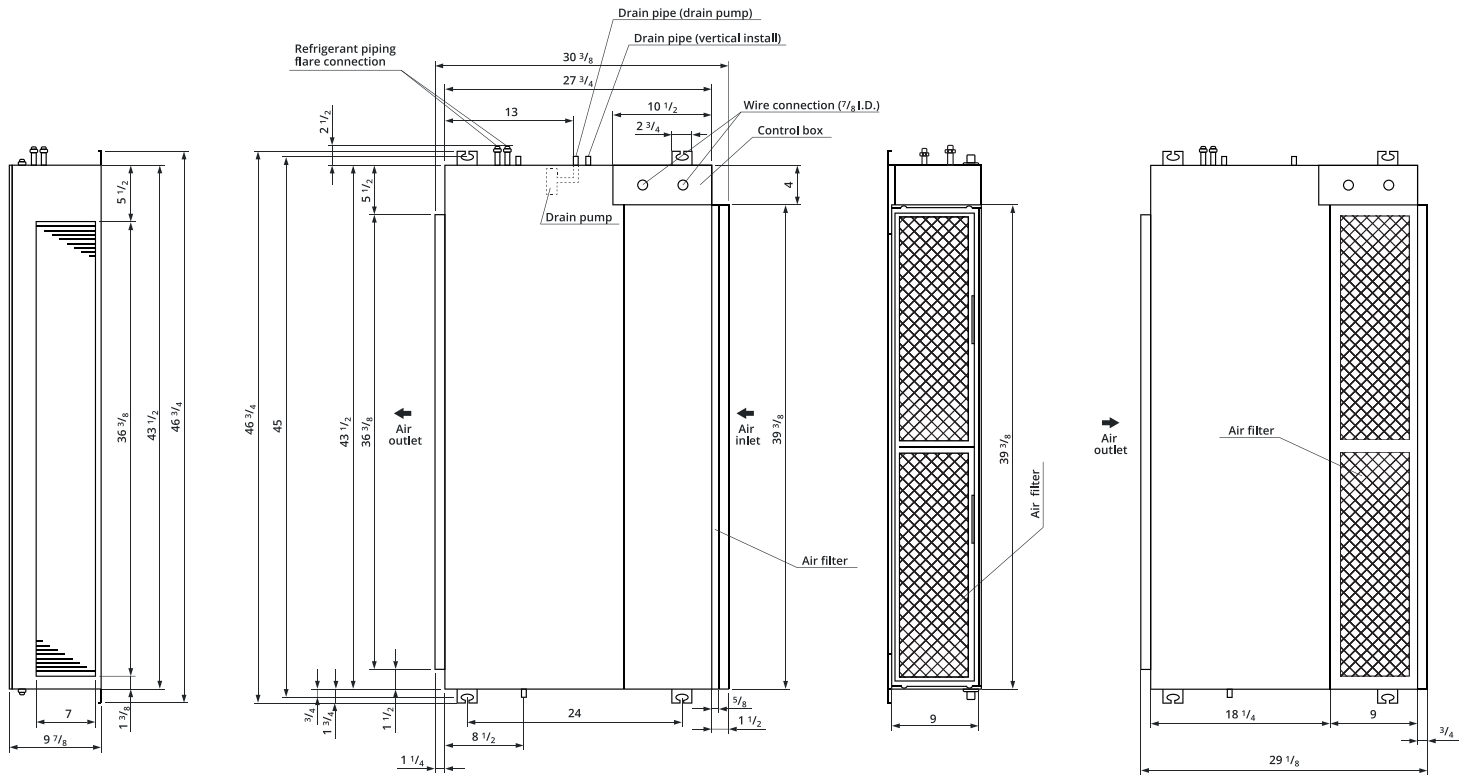
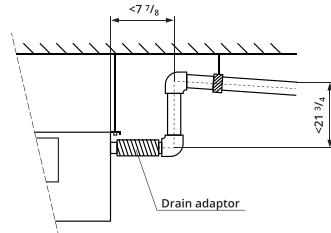
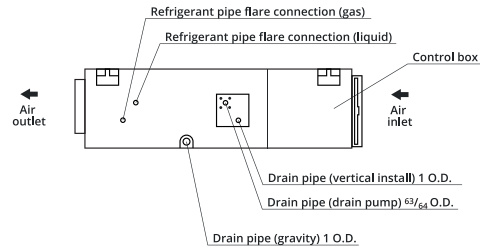

SUBMITTAL DATA SHEET	CH-M24DTUI	CH-24LCU/O
----------------------	------------	------------

OUTDOOR UNIT

